

PRODUCT INFORMATION PACKET

Model No: 145TTDR16021

Catalog No: GT4406

2 HP Close-Coupled Pump Motor, 3 phase, 3600 RPM, 230/460 V, 145JPV Frame, ODP
JP Motors



Nameplate Specifications

Output HP	2 Hp	Output KW	1.5 kW
Frequency	60/50 Hz	Voltage	230/460 V
Current	5.6/2.8 A	Speed	3510 rpm
Service Factor	1.15	Phase	3
Efficiency	86.5 %	Power Factor	78.5
Duty	Continuous	Insulation Class	F
Design Code	B	KVA Code	L
Frame	145JPV	Enclosure	Drip Proof
Thermal Protection	No	Ambient Temperature	40 °C
Drive End Bearing Size	6206	Opp Drive End Bearing Size	6203
UL	Recognized	CSA	Y
CE	Y	IP Code	22

Technical Specifications

Electrical Type	Squirrel Cage Inverter Rated	Starting Method	Line Or Inverter
Poles	2	Rotation	Reversible
Resistance Main	7.6 Ohms	Mounting	Round
Motor Orientation	Horizontal Or Shaft Down	Drive End Bearing	Ball
Opp Drive End Bearing	Ball	Frame Material	Rolled Steel
Shaft Type	JP	Overall Length	16.48 in
Frame Length	7.06 in	Shaft Diameter	0.875 in
Shaft Extension	7.31 in	Assembly/Box Mounting	F1 ONLY
Connection Drawing	A-EE7308	Outline Drawing	A-100231-706

This is an uncontrolled document once printed or downloaded and is subject to change without notice. Date Created:20/01/2021

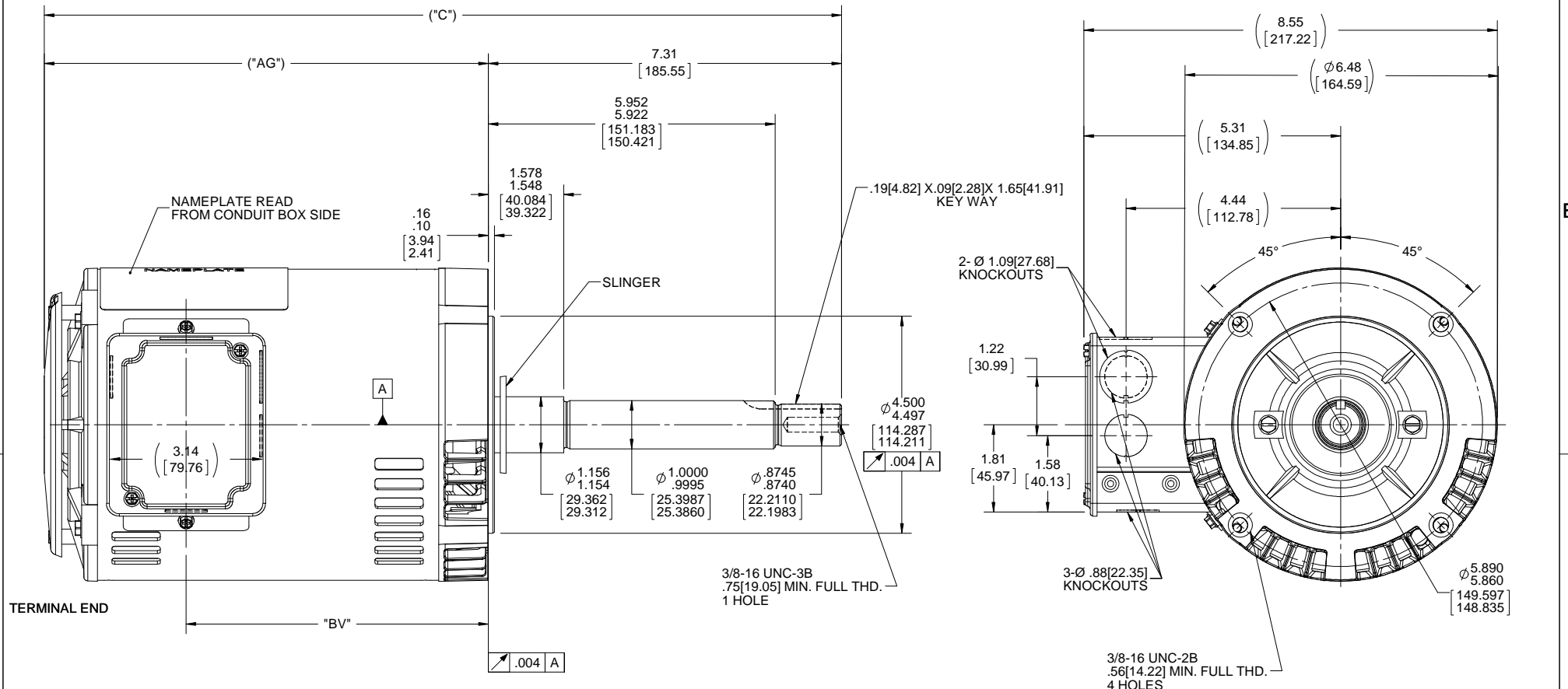

NOTE:
CONDUIT BOX CAN BE ROTATED IN 180° STEPS.

DASH NO.	"C"	"AG"	"BV"
656	15.99[406.14]	8.69[220.72]	5.75[146.05]
706	16.49[418.84]	9.19[233.42]	6.25[158.75]
756	16.99[431.54]	9.69[246.12]	6.75[171.45]
806	17.49[444.24]	10.19[258.82]	7.25[184.15]
856	17.99[456.94]	10.69[271.52]	7.75[196.85]
906	18.49[469.64]	11.19[284.22]	8.25[209.55]

DRAWING REVISION H	REVISION BY A. KEETHA	DATE 02/12/2018
ECO ECO-0143026	APPROVED BY PST	DATE 04/11/2018
ECO DESCRIPTION OUTLINE CONVERSION PROJECT		
<small>COPYRIGHT REGAL BELOIT AMERICA, INC. ALL RIGHTS RESERVED. PROPRIETARY AND CONFIDENTIAL INFORMATION - THIS DOCUMENT IS THE PROPERTY OF REGAL BELOIT AMERICA, INC. ("OWNER") AND CONTAINS OWNER'S PROPRIETARY INFORMATION. ANY PERSON, CORPORATION OR OTHER FIRM RECEIVING IT IS DEEMED, BY RECEIVING IT, TO AGREE THAT IT, AND/OR ANY PART OF IT, SHALL NOT BE DISCLOSED TO ANY PERSON, CORPORATION OR OTHER ENTITY, DUPLICATED, AND/OR USED, EXCEPT AS EXPRESSLY APPROVED IN WRITING IN ADVANCE BY OWNER. THIS DOCUMENT SHALL BE RETURNED TO OWNER UPON REQUEST. IT MAY BE SUBJECT TO CERTAIN RESTRICTIONS UNDER APPLICABLE EXPORT CONTROL LAWS AND REGULATIONS.</small>		

TOLERANCES UNLESS OTHERWISE SPECIFIED:		
DEC.	INCH	mm
.X	+0.1	[+2.5]
.XX	+0.03	[+0.76]
.XXX	+0.005	[+0.127]
.XXXX	+0.0005	[+0.0127]
REMOVE BURRS & BREAK SHARP EDGES: .003/.015 [0.076/.381] X 45°		
CORNER FILLETS: R.02 [51]		
MACHINED SURFACES: 200 INCH/mm 5.1		
mm SHOWN IN [BRACKETS]		

DRAWN BY BRH	DATE 10-24-1995
APPROVED BY GK	DATE 11-16-1995
REFERENCE 100231	THIRD ANGLE PROJECTION

Regal Beloit America, Inc.	
DESCRIPTION OUTLINE 140 FRAME-BB-DR.PR-3Ø-C'FACE-JP EXT	
MATERIAL	PROCESS/FINISH
SIZE B	DRAWING NUMBER 100231
SHEET 1 OF 1	

EE7308

THREE PHASE
DUAL VOLTAGE MOTOR

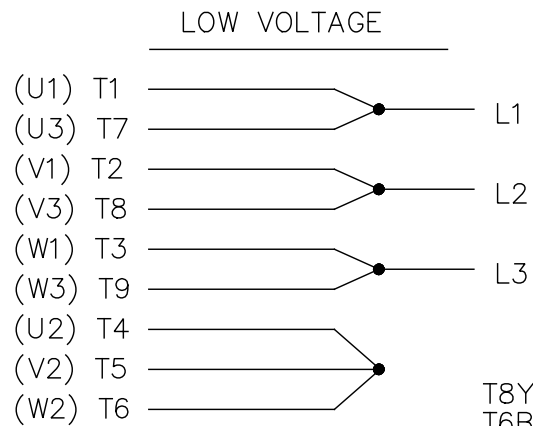

VIEW OF TERMINAL END

REF.
WINDING DIAGRAM

T8Y, T2Y, T2BL, T4BX, T2EC, T2G
T6BZ, T2B, T6BL, T4AV, T6B, T4B

OPTIONAL CORD
CONNECTION

L1 — WHITE
L2 — RED
L3 — BLACK

NO.	REVISION	BY & DATE	CHK	ANG	TOLERANCES UNLESS SPECIFIED		FINISH	DRAWN RM 11/20/1990				
					DEC.	INCHES						
5	CHG TO REGAL LOGO	SL 09/10/2015	AB					CHK ML 11/21/1990				
4	REVISED IEC NOTATIONS	MSG 11/15/2011	CMN	.X	±.1			APPD SAS 04/24/2003				
3	ADDED IEC NOTATIONS... (U1), (V1) ETC. MU95194	MSG 5/10/2010	MJS	.XX	±.02		TITLE CONNECTION DIAGRAM	SCALE 1=1				
2	ADDED THE OPTIONAL CORD CONNECTION MU46318	RDH 04/24/2003	DRS	.XXX	±.005		3Ø - DUAL VOLTAGE MOTOR	REF				
1	REDRAWN	RM 11/20/1990		.XXXX	±.0005		MAT'L.	FMF				
					±7'30"			PREV				
THIS DRAWING IN DESIGN AND DETAIL IS OUR PROPERTY AND MUST NOT BE USED EXCEPT IN CONNECTION WITH OUR WORK ALL RIGHTS OF DESIGN AND INVENTION ARE RESERVED THIS IS AN ELECTRONICALLY GENERATED DOCUMENT - DO NOT SCALE THIS PRINT							RFP	CAD FILE ee7308	SIZE A	DRAWING NO. EE7308	PAGE OF 5	REV. 5
							DIST WP					



Regal Beloit America, Inc.

** Subject to change without notice.

Data Sheet

Date: 16-06-2017
 Customer: _____
 Attention: _____
 Submitted by: FAREEDA DUDEKULA



145TTDR16021

Submittal

Data @ 460 V

Motor Load Data									
Load	0%	25%	50%	75%	100%	115%	125%	LR	
Current (Amps)	1.50	1.70	2.00	2.30	2.80	3.1	3.3	24.2	
Torque (ft-lb)	0.00	0.71	1.50	2.20	3.0	3.5	3.8	9.0	
RPM	3600	3580	3560	3540	3510	3,500	3495	0	
Efficiency (%)		74.5	83.0	86.0	86.5	86.5	86.0		
P.F. (%)	10.0	37.0	58.0	71.0	78.5	81.0	83.0	64.5	

Motor Speed Data						Information Block				
	LR	Pull-Up	BD	Rated	Idle					
Speed (RPM)	0	1500	2570	3510	3600	HP	2.0			
Current (Amps)	24.2	21.8	16.2	2.80	1.50	Sync. RPM	3600			
Torque (ft-lb)	9.0	11.0	12.8	3.0	0.00	Frame	145			
						Enclosure	DP			
						Construction	TDR			
						Voltage	30/460#190/38V			
						Frequency	60 Hz			
						Design	B			
						LR Code letter	L			
						Service Factor	1.15			
						Temp Rise @ FL	38 ° C			
						Duty	CONT			
						Ambient	40 ° C			
						Elevation	1,000 feet			
						Rotor/Shaft wk ²	0.03 Lb-Ft ²			
						Ref Wdg	ZT224 DR			
						Sound Pressure @ 1M	68 dBA			
						VFD Rating	CONSTANT 2:1			
						Outline Dwg	A-100231-706			
						Conn. Diag	A-EE7308			
						Additional Specifications:				
						0				
						365THFS8036				
						EQUIV CKT (OHMS / PHASE)				
						R1	R2	X1	X2	Xm
						0.0000	0.0000	0.0000	0.0000	0.0000

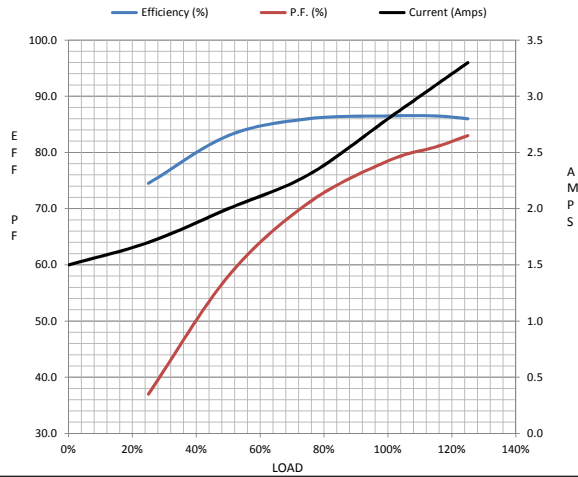

HP	2.0			
Sync. RPM	3600			
Frame	145			
Enclosure	DP			
Construction	TDR			
Voltage	30/460#190/38V			
Frequency	60 Hz			
Design	B			
LR Code letter	L			
Service Factor	1.15			
Temp Rise @ FL	38 ° C			
Duty	CONT			
Ambient	40 ° C			
Elevation	1,000 feet			
Rotor/Shaft wk ²	0.03 Lb-Ft ²			
Ref Wdg	ZT224 DR			
Sound Pressure @ 1M	68 dBA			
VFD Rating	CONSTANT 2:1			
Outline Dwg	A-100231-706			
Conn. Diag	A-EE7308			
Additional Specifications:				
0				
365THFS8036				
EQUIV CKT (OHMS / PHASE)				
R1	R2	X1	X2	Xm
0.0000	0.0000	0.0000	0.0000	0.0000

